

VirtualSCADA[®] VSU-485G
USB to RS422/485 Isolated Converter
User Manual

Revision 1.01.00

Table of contents

Warranty and support	3
Product return	3
1 About the VirtualSCADA USB to RS422/485 Converter	4
1.1 General	4
1.2 Mounting	5
1.3 Connectors / Indicators.....	6
1.3.1 Terminal Connections	6
1.3.2 LED – Status Indicators.....	7
2 VSU-485G Device Configuration	8
2.1 Install USB Driver	8
2.2 RS485 Network – Single Device (RS485) Half Duplex Configuration.....	8
2.3 RS485 Network – Single Device (RS422) Half Duplex Configuration.....	9
2.4 RS422 Network – Single Device (RS422) Full Duplex Configuration	10
2.5 RS485 Network – Multiple Converters - Half Duplex Configuration	11
2.6 RS422 Network – Multiple Converters - Full Duplex Configuration.....	12
2.7 RS422/485 Line Balancing	13
APPENDIX A: TECHNICAL SPECIFICATIONS	14

Warranty and support

To obtain fast and simple support for your **VirtualSCADA U-485G** products visit our website at www.VirtualSCADA.com

Product return

If you experience any problems with a **VirtualSCADA U-485G** device and wish to have it repaired or exchanged, please follow these steps:

- Obtain a RMA Return Number, RMA, www.VirtualSCADA.com
- To get this number you'll need to provide some information about the problem you have, contact information etc.
- Print the "RMA Number" and send it to us together with the product. Make sure the RMA is visible on the outside of the package, and that the delivery is pre-paid, otherwise the delivery won't be accepted by us. Also provide evidence of original purchase.
- If the faulty product is covered by the 12-month warranty, we will repair or exchange the device and return it within 30 days. If the product is not covered by Warranty we will advise an estimated repair cost.

VirtualSCADA Software LLC standard terms and conditions apply for this product.

1 About the VirtualSCADA USB to RS422/485 Converter

1.1 General

The VirtualSCADA **VSU-485G** is an isolated USB to RS422/485 converter that can be used for communication between a PC and devices that have a RS485 or RS422 communication port. Multiple **VSU-485G** converters may be used to create a RS485 / RS422 network.

Features

- Supports Windows 95, 98, NT, 2000, XP, Vista and 7
- Supports Apple Macintosh
- Supports Linux
- Isolated via opto-couplers
- Din-rail mount
- Support for other VirtualSCADA products
- USB port supplies power to the converter
- 300BPS ~1MBPS, auto tuning
- PC support for one U-485G

1.2 Mounting

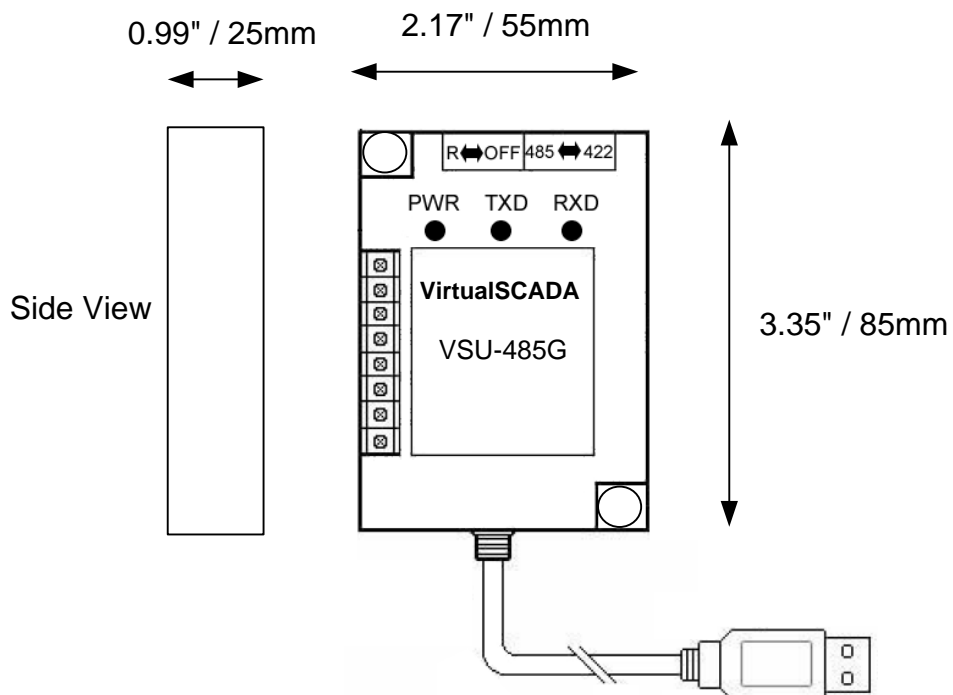

Mounting holes Diameter: 0.177" / 4.5mm

Dimensions:

3.35" x 2.17" x 0.99" (H x W x D)

85mm x 55mm x 25mm (H x W x D)

Snap the **VirtualSCADA U-485G device** onto the DIN-rail

1.3 Connectors / Indicators

1.3.1 Terminal Connections

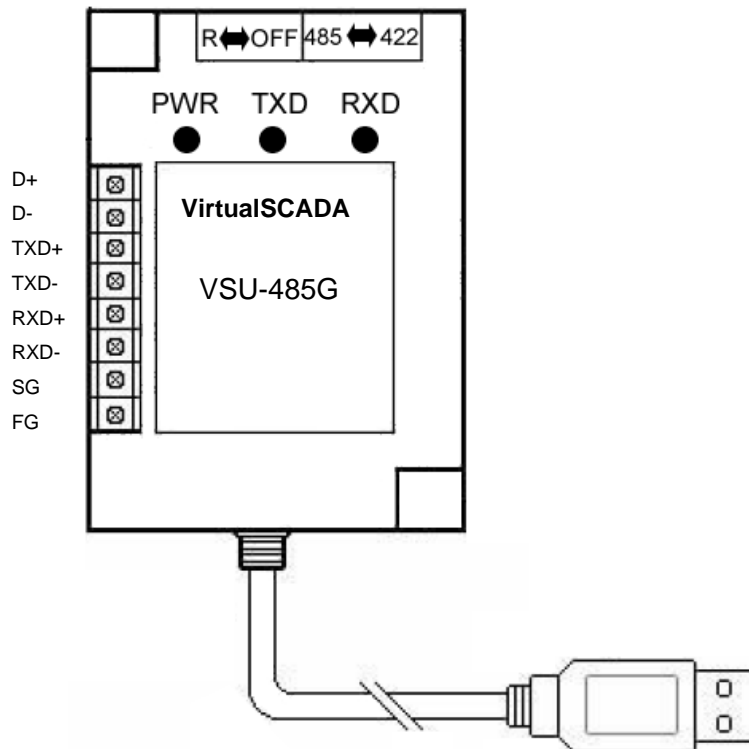

Terminal	Signal
D+	RS485 Signal +
D-	RS485 Signal -
TXD+	RS422 Signal Send +
TXD-	RS422 Signal Send -
RXD+	RS422 Signal Receive +
RXD-	RS422 Signal Receive -
SG	Signal Ground
FG	Ground

1.3.2 LED – Status Indicators

Name	Color	Function
Power	Off	No power
	On	Power supply turned on to converter
Rx	Off	No data received
	On / Flashing	Receiving data
Tx	Off	No data transmitted
	On / Flashing	Transmitting data

2 VSU-485G Converter Configuration

2.1 Install USB Driver

Plug USB to RS485 converter into your computer's USB port

Your computer system will ask you for the device driver location. Please point to the location of the driver file on the CD-Rom or download the driver from www.virtualscada.com. Your computer system will update the driver list and install the USB converter automatically. A new virtual com port will now be available on your PC.

To check if the USB driver is installed successfully, please follow these steps:

- go to your computer's Control Panel
- click on System
- click on Hardware
- click on Device Manager
- click on Ports (COM & LPT)
- Next unplug the USB device you just installed. If one of the communication port(s) disappears under the Port (COM & LPT), then the driver has been installed successfully.

Make sure to note which communication port is used by the USB converter.

2.2 RS485 Network – Single Device (RS485) – Half Duplex Configuration

Set switch K1 to '485' and K2 to "OFF" when using the VirtualSCADA VSU-485G converter with a single device (e.g. AC Drive, PID Controller, I/O Module, etc...). Connect D+ from the VSU-485G to the "A / + / D+ / DX+" RS485 terminal of the device and D- to "B / - / D- / DX-"

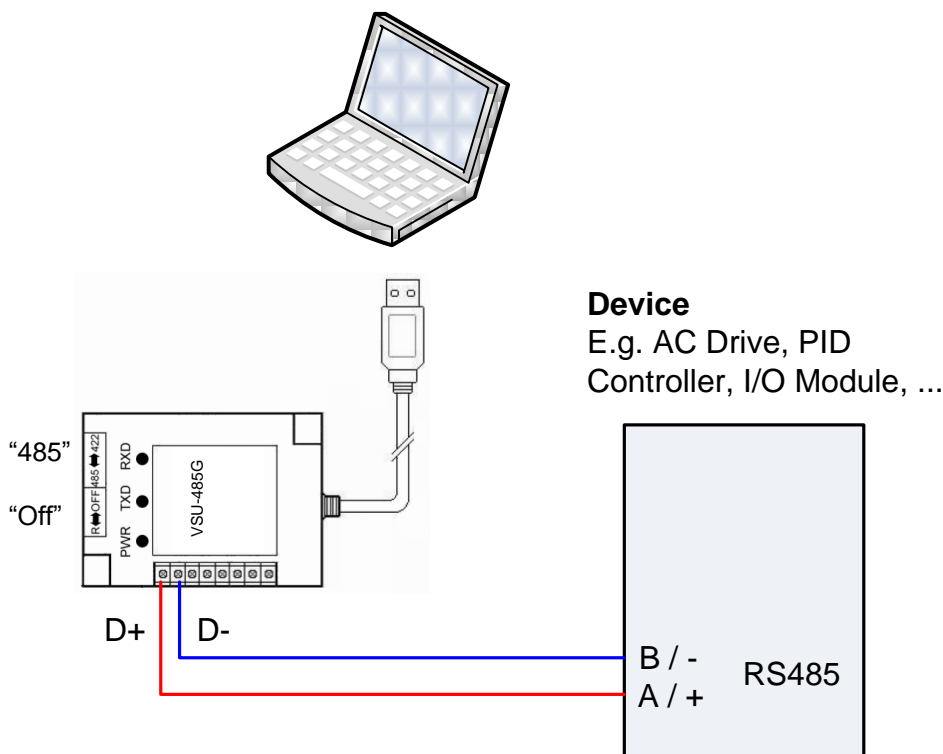

2.3 RS485 Network – Single Device (RS422) – Half Duplex Configuration

Set switch K1 to '485" and K2 to "OFF" when using the VirtualSCADA VSU-485G converter with a single device (e.g. AC Drive, PID Controller, I/O Module, etc...). Connect D+ from the VSU-485G to the "Tx+ / A / + / D+ / DX+" RS485 terminal of the device and D- to "Tx- / B / - / D- / DX-". Install jumper on the device from TX+ to Rx+ and Tx- to Rx-.

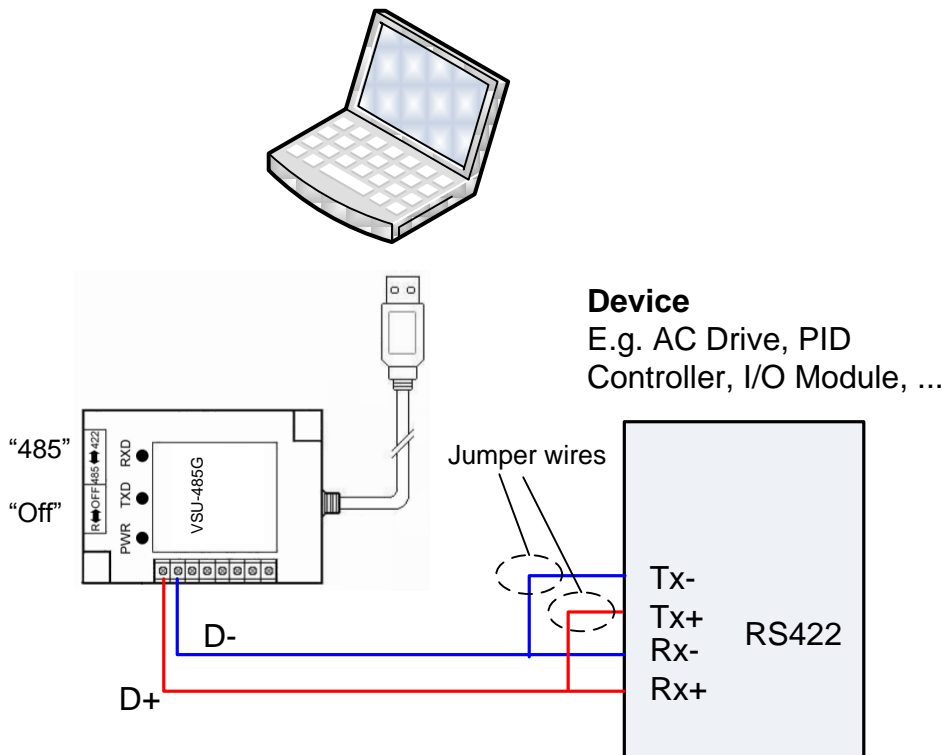

2.4 RS422 Network – Single Device (RS422) – Full Duplex Configuration

Set switch K1 to '422' and K2 to "OFF" when using the VirtualSCADA VSU-485G converter with a single device (e.g. AC Drive, PID Controller, I/O Module, etc...). Connect Tx+ from the VSU-485G to the "Rx" of the device, Tx- to Rx- of device, Rx+ to Tx+ of device and Rx- to Tx- of device.

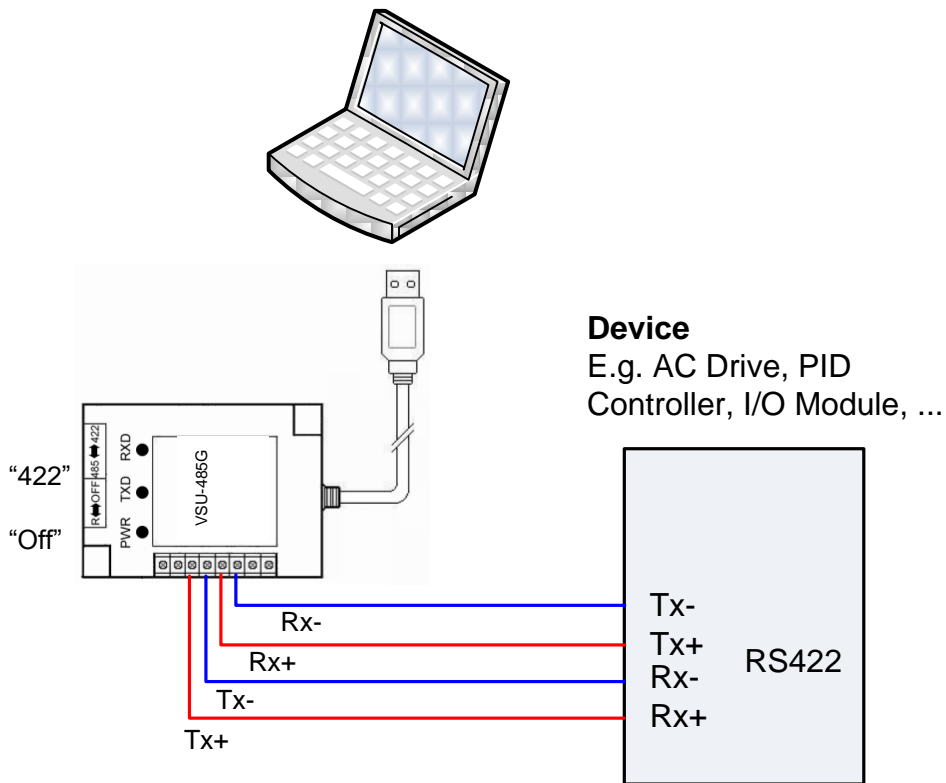

2.5 RS485 Network – Multiple Converters – Half Duplex Configuration

Set switch K1 to '485' and K2 to "OFF" when using multiple VirtualSCADA VSU-485G converter on RS485 mode. Connect D+ from the VSU-485G to the "D+" of the other VSU-485G converters and connect D- from the VSU-485G to the "D-" of the other VSU-485G converters on the network.

The first and last VSU-485G converter on the network should have the termination resistor switch K2 set to "R".

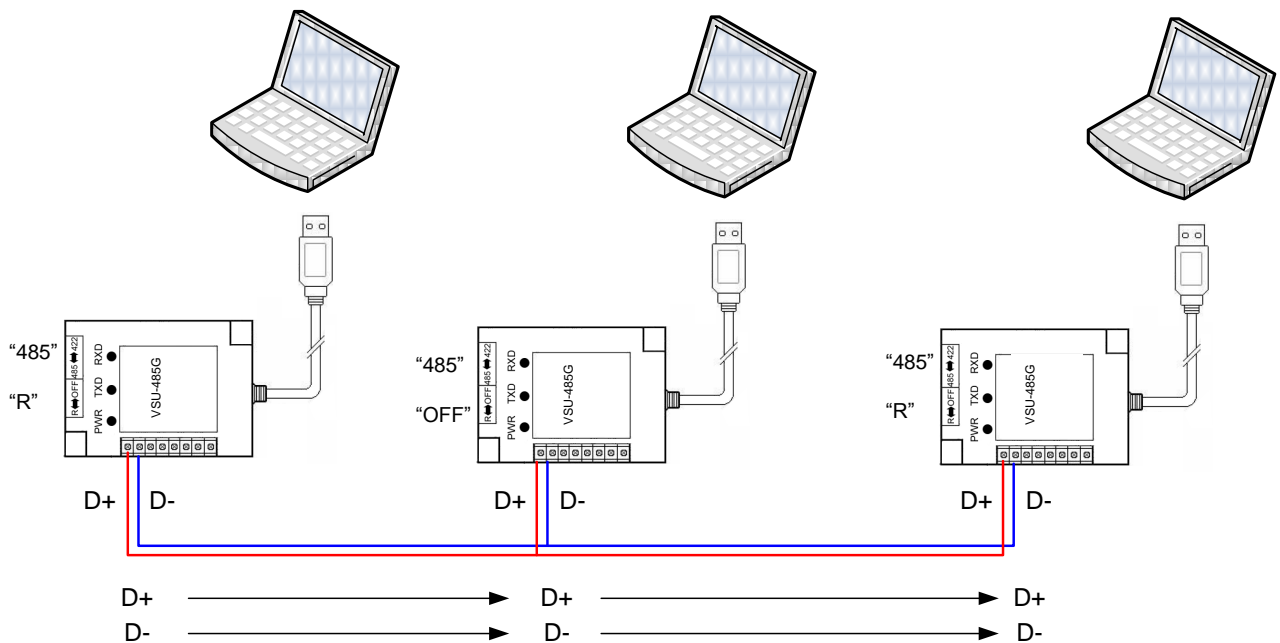

2.6 RS422 Network – Multiple Converters – Full Duplex Configuration

Set switch K1 to '422' when using multiple VirtualSCADA VSU-485G converter in RS422 mode. The network can only have one master. Connect Tx+ from the master VSU-485G to "Rx+" of the other VSU-485G converters, Tx- from the master VSU-485G to "Rx-" of the other VSU-485G converters, Rx+ from the master VSU-485G to "Tx+" of the other VSU-485G converters and Rx- from the master VSU-485G to "Tx-" of the other VSU-485G converters on the network.

The first and last VSU-485G converter on the network should have the termination resistor switch K2 set to "R".

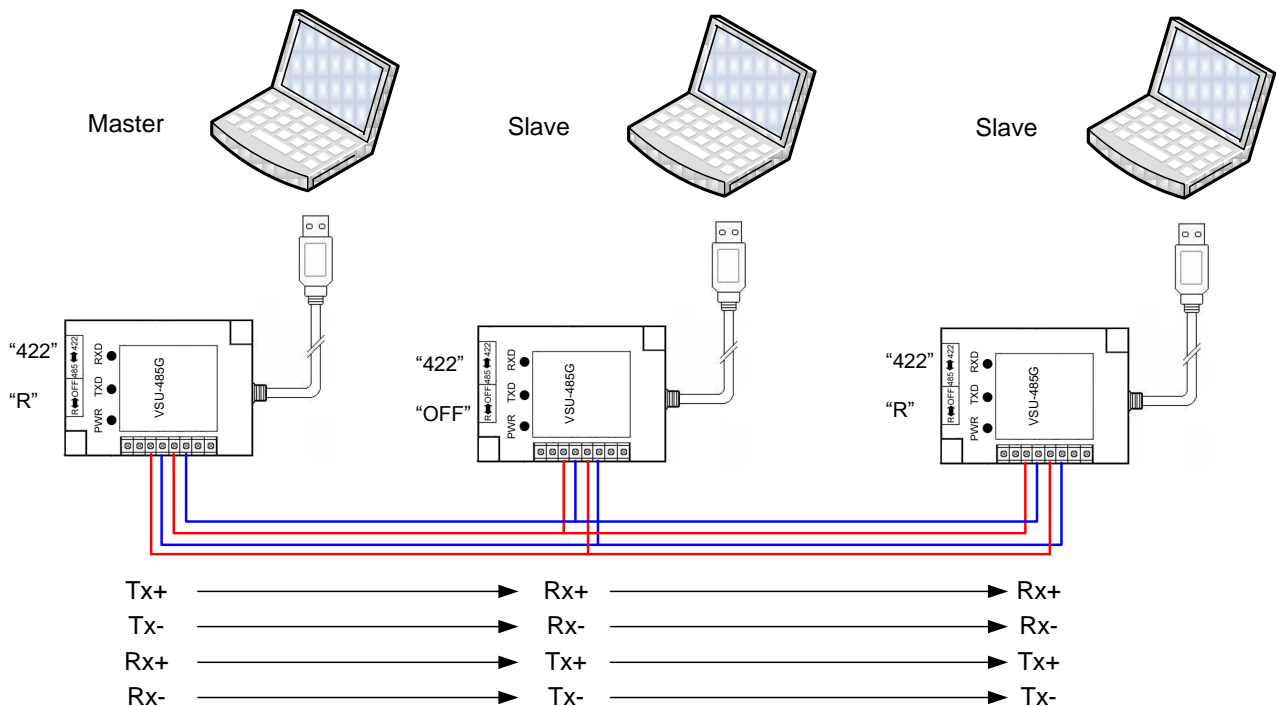

2.7 RS422 / RS485 Device Line Balancing

In case your RS422/RS485 device does not have line balancing resistors built-in additional line balancing resistors must be used for proper operation. Install as per the following diagram.

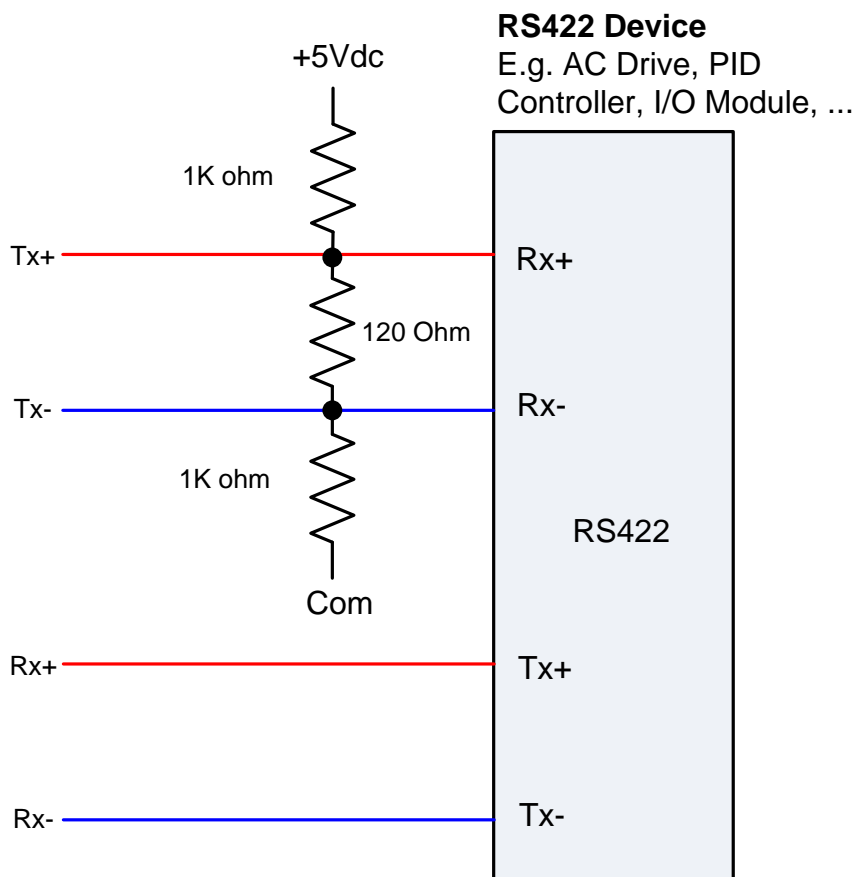
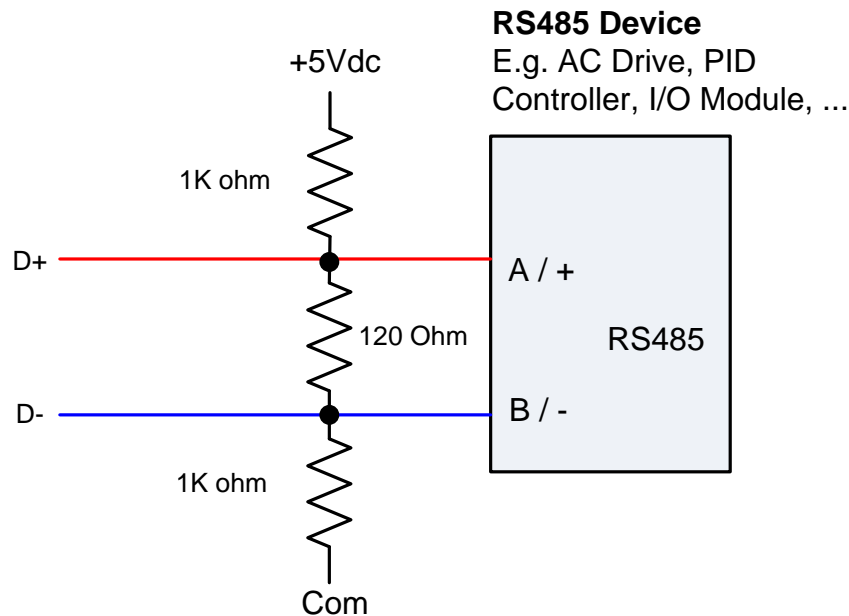

APPENDIX A: Technical Specifications

Power Supply:	Supplied by the USB Port
Isolation:	700V continuous / 3.5kV Pulse
Surge Protection:	400W voltage surge Protection from static voltage
Max. Communication Distance:	9843ft /3000m (4800bps) 6561ft /2000m (9600bps)
Communication Port:	4 wire Full Duplex RS422 connection 2 wire Half Duplex RS485 connection
Communication Speed:	300bps – 1Mbps
Termination:	120 Ohm terminating resistor built-in can be activated with switch.
Maximum Communication Network:	32 Nodes
UART:	Data bits: 7 or 8 Stop bits: 1 or 2 Parity: None, Even, Odd
Status Lights:	Power, Receive, Transmit
USB Cable Length:	23" (0.6m)
Operating Temperature:	-4F – 158F / -20°C to 70°C
Humidity:	10% to 90% (non-condensing)
Installation:	Din rail 35mm
Dimensions:	3.35" x 2.17" x 0.99" (H x W x D) 85mm x 55mm x 25mm (H x W x D)

VirtualSCADA®